

YONG YUAN VALVE

STAINLESS STEEL FLOATING BALL VALVE

SERIES: #AQ41F-150LB



SPECIFICATIONS:

- DESIGN AND MANUFACTURE (FULL PORT)
- FACE TO FACE:ANSI B16.10
- FLANGE:ANSI B16.5
- PRESSURE TEST:API 598 OR ISO5208
- FLANGE FACINGS AVAILABLE ON REQUEST

SPECIFICATIONS

NOMINAL PRESSURE	150 LBS	2.0 Mpa
SHELL STRENGTH (WATER)	348 Psi	3.0 Mpa
SEALING TEST (WATER)	255 Psi	2.2Mpa
AIR SEAT PING (AIR)	60~105 Psi	0.4~0.7 Mpa

Parts & Materials

No.	Part	Material
1	BODY	CF8
2	STUD BOLT	STAINLESS STEEL
3	NUT	STAINLESS STEEL
4	BONNET	CF8
5	SPIRAL WOUND	PTFE
6	SEAT	RPTFE
7	BALL	SS304
8	STEM	SS304
9	PACKING	PTFE
10	PACKING	PTFE
11	PACKING	PTFE
12	GLAND	CF8
13	HEX BOLT	STAINLESS STEEL
14	LOCATOR CARD	STAINLESS STEEL
15	FLEXIBLE WASHER	65Mn
16	HANDLE	DUCTILE IRON

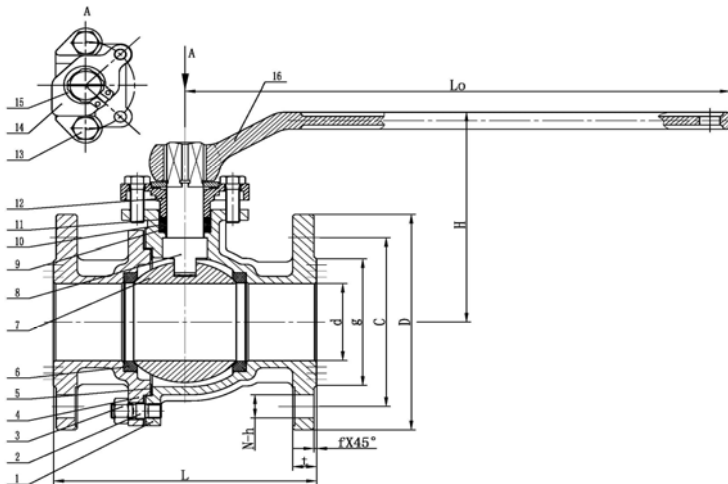

DIMENSIONS(mm)

DN	L	D	C	g	d	N	h	t	f	H	S	L0
15	108	89	60.5	35	15	4	15	12	2	88	11	160
20	117	98	70	43	20	4	15	12	2	90	11	160
25	127	108	80	51	25	4	15	12	2	94	11	160
32	140	117	89	64	32	4	15	13	2	99	11	220
40	165	127	99	73	40	4	15	15	2	124	17	250
50	178	152	121	92	50	4	19	16	2	133	17	250
65	190	178	140	105	65	4	19	18	2	174	22	400
80	203	190	153	127	80	4	19	19	2	187	22	400
100	229	229	191	157	100	8	19	24	2	210	22	400
125	356	254	216	186	125	8	22	24	2	221	24	500
150	394	279	242	216	150	8	22	26	2	247	24	500
200	457	343	299	270	200	12	22	29	2			

Add:No.87-89,Mingyuan North Avenue, Economic Development Zone, Yongkang,Zhejiang Province,China
 Tel:0086-579-8715288 0086-579-8725688 Fax:0086-579-87151442
 E-mail:cnyvc@cnyvc.com yu@cnyvc.com Http:www.yongyuanvalve.com